

Wetlands Commission Follow Up From Site Visit | 66 Upper Church Hill Road

Justin Schwarz <justinschwarz@me.com>

Wed 8/4/2021 12:56 PM

To: Shelley White <swhite@washingtonct.org>

📎 2 attachments (2 MB)

66UpperChurchSite Plan_Revised 8-4-21.pdf; EquipmentSlab_Filter.pdf;

Hi Shelley -

The Wetlands Commission came yesterday for a site visit and had some follow up questions for our pool company.

They asked to see the Backwash for Discharge. The pool company said, "no backwash is necessary, we use a cartridge filter (see attached equipment/filter sheet)."

They requested a trenching line from the equipment to the pool be placed in the map (see attached revised map).

They wanted to know about the pool filtration - it is a cartridge (see attached equipment/filter sheet).

They requested a construction sequence from the pool contractor (see attached Wagner Pools standard construction sequence).

Please let me know if there are any other questions or clarifications that we can provide.

Thank you,
Justin Schwarz

CONSTRUCTION SEQUENCE

01. MARK BOUNDARY OF WORK TO BE PERFORMED & CONTACT DIG SAFE (OR RELEVANT AGENCY) 72 HRS PRIOR TO BREAKING GROUND TO VERIFY LOCATION OF U.G. UTILITIES.
02. INSTALL SITE PROTECTION MEASURES: SILT FENCE, ANTI-TRACK PAD, TREE PROTECTION, CONSTRUCTION FENCE, ETC; IF REQUIRED, SCHEDULE INSPECTION.
03. DEMOLISH EXISTING STRUCTURES, FEATURES, VEGETATION, ETC. AS REQUIRED. DECONSTRUCT MATERIALS SPECIFIED FOR LATER USE & STAGE NEATLY IN APPROVED AREAS. STRIP & STOCKPILE TOPSOIL IN SPECIFIED AREA; SEE GRADING NOTES.
04. LAYOUT & EXCAVATION: MEASURE & MARK OUTLINES OF DESIGN FEATURES WITH APPROPRIATE OVER DIG MARGINS. EXCAVATE & STAGE CAST MATERIALS FOR LATER USE OR TRANSPORT OFF SITE.

05. FOOTINGS & FOUNDATIONS: FORMWORK, STEELWORK, CONCRETE POURS, & GUNITE POOL & SPA SHELLS. INSTALLATION OF REQUISITE UTILITY FEATURES (DRAINAGE, IRRIGATION, PLUMBING, & ELECTRICAL) TO RUN CONCURRENTLY WHEREVER APPLICABLE. BACKFILL & INSTALL BASE MATERIALS FOR FINISH TREATMENTS.
06. ABOVE-GRADE HARDSCAPE SYSTEMS: INSTALL TERRACES & WALLS, STOOPS & STAIRS, FIRE PITS, PERGOLAS, WATER FEATURES, GRILLS, ETC WITH REQUISITE UTILITY FEATURES AS REQUIRED.
07. AT-OR-NEAR-GRADE HARDSCAPE SYSTEMS: POOL COPING, WET & DRY PAVING SYSTEMS, CURBS, APRONS, DRIVEWAYS, ETC. TO RUN CONCURRENTLY WITH REQUISITE UTILITY FEATURE INSTALLATIONS.
08. SEEDING & PLANTING: SPREAD TOPSOIL & FINE GRADE ALL LANDSCAPED AREAS; SEED & PLANT AS REQUIRED. (REFERENCE PLANTING NOTES).
09. PROJECT CLOSEOUT: REMOVE EROSION CONTROL MEASURES, FINAL CLEANUP, & WALK THROUGH WITH OWNER, LANDSCAPE ARCHITECT, & OTHER RELEVANT PROJECT REPS.

EROSION CONTROL NOTES

01. PRIOR TO THE COMMENCEMENT OF ANY WORK, SITE PROTECTION MEASURES SHALL BE INSTALLED & PRESENTED FOR INSPECTION BY RELEVANT REGULATORY AGENCIES. CONTRACTOR SHALL INSPECT, MAINTAIN, & REPAIR PROTECTION MEASURES ACROSS THE DURATION OF THE PROJECT.
02. NO DISTURBANCES OF ANY KIND SHALL OCCUR OUTSIDE THE APPROVED BOUNDARY OF WORK TO BE PERFORMED. RE STABILIZATION, WHENEVER REQUIRED, SHALL BE SCHEDULED AND PERFORMED AS SOON AS POSSIBLE.
03. DISTURBED AREAS EXPOSED FOR MORE THEN 30 DAYS SHALL BE PROTECTED WITH TEMPORARY VEGETATIVE COVER & SEEDED WITH ANNUAL RYE GRASS AT A RATE OF 1 LB PER 1,000 SF OR 40 LBS PER ACRE.

* * * * *

Justin Schwarz | 917.224.4822

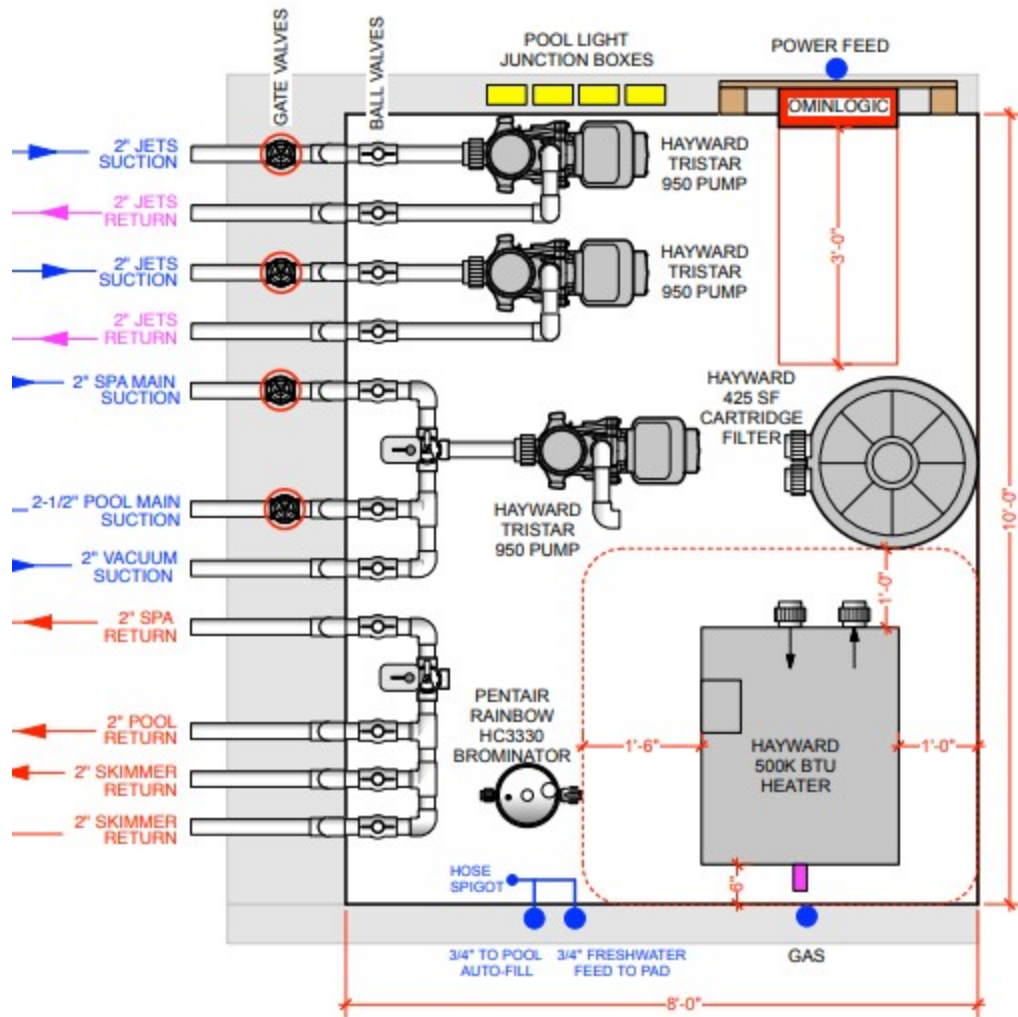

FILTER EQUIPMENT PAD DIAGRAM

DATE: 01/15/2015



WAGNER POOLS
 101 NOROTON AVE. DARIEN, CT 06820
 TEL. (203) 655-0766

SCHWARTZ RESIDENCE
 66 CHURCH HILL RD WASHINGTON DEPO, CT 06794

SCALE	N.T.S
DATE	7/29/21
REVISED	8/4/21
ADDED UTILITY TRENCH	
DRAWN	GIWT
SHEET NO.	

P-1

SITE PLAN

